



CENTRASIP

Centralized Cleaning

Pipe Cleaning
Tank Cleaning
Equipment Cleaning

Customized
Plant
Solutions



Automation System Hellas

be Clean
be Safe
be Flexible

CENTRASIP

The complete choice
for the food industry

(Dairy, Beverage, Brewery etc.)

The CENTRASIP Cleaning In Place central unit: an automatic and versatile system that cleans piping, tanks, filling machines and other equipment used in the food industry. The unit is fully adjustable and the user is allowed to alter and save the main cleaning parameters as volume, duration, temperature and conductivity.

CENTRASIP is prefabricated and premounted on a stainless steel frame and is easily installed and ready to use in any industrial environment. Special focus is given to safety and energy economy.

Innovative Working Principle

The CENTRASIP unit is manufactured according to the latest food industry standards and covers a wide range of cleaning demands. It comprises of all the necessary equipment as pump, valves, heat exchanger, specialized instruments, water and chemical solutions tanks in order to achieve maximum cleaning effects while keeping the running costs to a minimum.

The automated cleaning program is completed by different steps that maintain different and changeable characteristics in terms of circuit volume, recirculation duration, cleaning temperature and conductivity.

The CENTRASIP system can be totally customized to meet individual needs and specifications by choosing one or more of the various available options. Installation is simple and requires minimum space. It is a fully flexible system that can be put easily in operation without special technical knowledge.

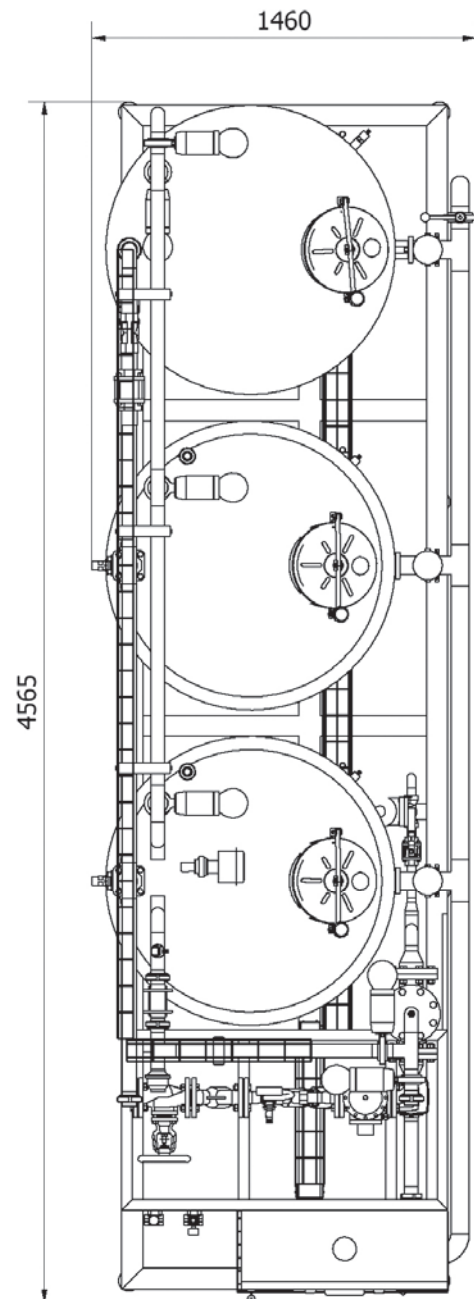

Standard Design Features

- Fully automatic operation
- Connected with detergent tanks
- Single cleaning line
- HMI touch panel 6"
- Operator language in English
- 5 cleaning programs for every circuit
- Software for up to 10 different cleaning circuits
- Individual circuit parameter adjustment
- Manual-remote operation for maintenance
- Operation hours / Maintenance alarm
- Operation interlocks
- Last CIP per circuit indication
- Temperature, flow, conductivity trends
- Standard / programmable alarms
- Complete documentation in English



Smart Automation Control

The CENTRASIP unit is controlled by a PLC that receives all the required data and executes safely the necessary operations.

Navigation can be easy through user friendly menus and managing functions can vary for different user access levels. All the important information is at the user's disposal at real time. Historic data and reports can be available locally or remotely.

Standard Units

- CENTRASIP-100 for up to 10 m³/hr, DN40, tanks 2.000 Lt each
- CENTRASIP-150 for up to 15 m³/hr, DN50, tanks 5.000 Lt each
- CENTRASIP-300 for up to 30 m³/hr, DN65, tanks 5.000 Lt each
- CENTRASIP-400 for up to 40 m³/hr, DN80, tanks 10.000 Lt each
- CENTRASIP-600 for up to 60 m³/hr, DN100, tanks 10.000 Lt each
- CENTRASIP-1000 for up to 100 m³/hr, DN125, tanks 15.000 Lt each

Standard units can be either installed with the standard recommended technical specifications or customized using one or more of the available options.

Recommended Component Suppliers

- Bardiani pneumatic valves
- Samson steam analogue valve
- Alfa-Laval centrifugal pressure pump
- MBS tubular heat exchanger
- Rittal stainless steel electrical panel
- SIEMENS PLC
- SIEMENS touch screen

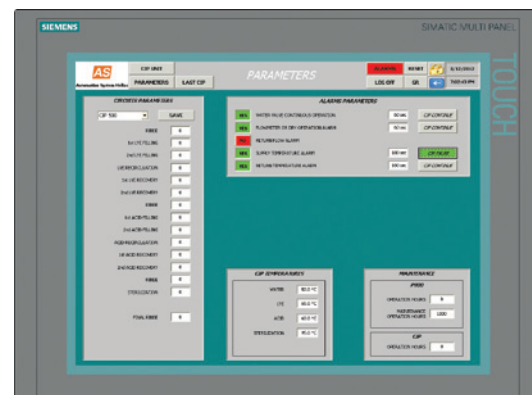
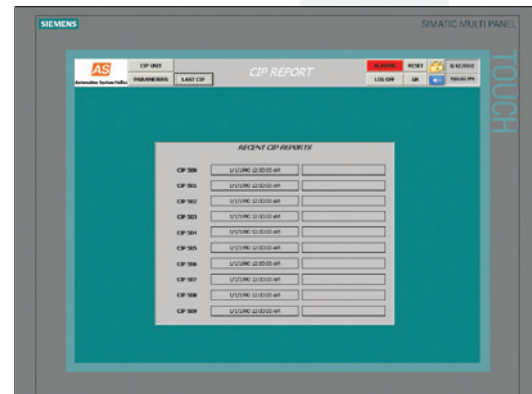

Options for Tailor-made

- Selection of different tank sizes
- Addition of separate cleaning lines
- Selection of approved component suppliers
- Chemical disinfectant dosing
- Solution preheating
- Touch panel up to 15"
- Industrial panel PC
- Connection with central SCADA
- Software for up to 32 different cleaning circuits
- Valve feedback
- Pump frequency regulation
- Tele-service modem
- Logging of data and alarms
- Standardized or customized reports
- Second operator language (if available)

Basic Requirements

- Steam starting from 400 kg/h at 3,5 bar
- Oil-free compressed air at 7 bar
- Power starting from 2,2 kW, 400V, 50Hz
- Water consumption ranges from 10.000 lit/hr
- **Dimensions (WxLxH):**
starting from 4.550 x 1.460 x 2.575 mm
- **Weight:** starting from 1.485 kg



NATC

Mechanical Engineering,
Automation & IT Solutions

www.natc.com.au

Mob: 0414 744 677 Tel: 03 9042 1373
Suite 13 / 70 Racecourse Road
North Melbourne VIC 3051



Automation System Hellas

Automation System Hellas
GR 57001, Thessaloniki, Greece
www.ashellas.com

Plant Engineering
Industrial Automation
Building Automation

Subject to change without prior notice
© Automation System Hellas 2013



Solution Partner

Automation

SIEMENS

